



29' Aerial Lifts

Chassis Features

- Light Duty Chassis
- Automatic or Standard Transmission
- Hydraulic Brakes
- All weather tires
- Gas or Diesel engine
- Front tow hooks
- Pintle Hook

Equipment Features

- Terex-Telelect T292, and T292I, and Telsta A28D
- Non-Insulated or Insulated
- 28' - 29' bottom of the bucket height
- Enclosed 1-man bucket w/ 300-350# capacity
- Telescopic Booms
- Emergency lowering system
- Hydraulic bucket tilt & rotation or gravity leveled
- Hydraulic tool - Insulated units
- 110v outlet at bucket - Non-insulated units
- Engine Start-Stop (various units)
- Torsion Bar
- Strobe Light

Reach Diagram

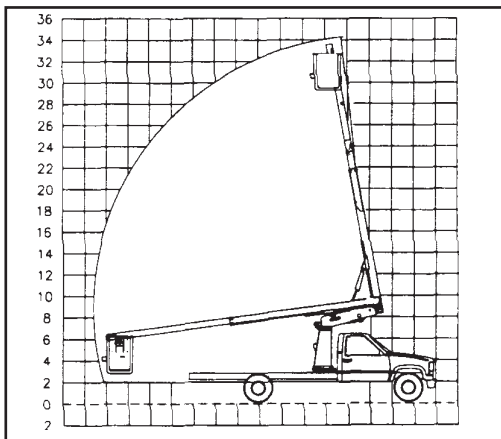

CAPACITIES & DIMENSIONAL DATA

	Side Mt.	End Mt.
<i>Bottom of Platform Height</i>	28.5	29.3
<i>Working Height</i>	33.5	34.3
<i>Horizontal Reach</i>	20.9	23.2
<i>Boom Travel (Above Horizontal)</i>		80°
<i>Boom Travel (Below Horizontal)</i>		-8